



---

## CERTIFICATE OF APPROVAL

### No CAF 109

---

This is to certify that, in accordance with  
TS00 General Requirements for Certification of Fire Protection Products  
The undermentioned products of

**Designated CERTIFIRE Approved Door and Blank Manufacturers  
as Converted by**

## **HICKMAN INDUSTRIES LIMITED**

**Fibercill. Unit 15, The Moorings, Hurst Business Park, Brierley Hill,  
West Midlands DY5 1UF**

**Tel: +44 (0) 1384 489542 Fax: +44 (0) 1384 489549**

Have been assessed against the requirements of the Technical Schedule(s)  
denoted below and are approved for use subject to the conditions  
appended hereto:

---

#### **SCOPE OF APPROVAL**

Approved for processing\* of fire  
doors and/or blanks  
manufactured by CERTIFIRE  
approved companies as specified  
in this certificate: Blank  
conversion, apertures; glazing of  
apertures and door frames

#### **TECHNICAL SCHEDULE**

TS10 Fire Resisting Door  
Assemblies with non- Metallic  
Leaves

**Signed and sealed for and on behalf of Warringtonfire Testing and Certification Limited**

**Paul Duggan  
Certification Manager**



Issued: 8<sup>th</sup> August 2000  
Reissued: 5<sup>th</sup> July 2022  
Valid to: 31<sup>st</sup> August 2022





## CERTIFICATE No CAF 109 HICKMAN INDUSTRIES LIMITED

### FIRE DOOR FRAMES & KITS

1. This approval relates to the provision of door frame kits for doors supplied by Premdor Crosby Limited, Vicaima Limited and JELD-WEN Limited. Subject to the undermentioned conditions, the door assemblies will meet the requirements as detailed in the relevant certificates.
2. This certification is designed to demonstrate compliance of the product or system specifically with Approved Document B (England and Wales), Section 2 of the Technical Standards (Scotland) and Technical Booklet E (N. Ireland). If compliance is required to other regulatory or guidance documents there may be additional considerations or conflict to be taken into account.
3. The certified doors for which the provision of door frame kits is approved are as following:

Certificate Number	Timber Door Product
CF198	Premdor Colonist/Classique/Canterbury
CF218	Vicaima FD30 Standard Duty Core
CF160	JELD-WEN FD30 Timber Doors
CF192	JELD-WEN FD30 Timber Doors (Tubeboard)

The scope of approval and field of application for the doors is contained in the above referenced certificates.

4. The door frame kits with the specified door(s) are approved on the basis of:
  - (i) initial type testing
  - (ii) audit testing at the frequency specified in TS10
  - (iii) a design appraisal against TS10
  - (iv) Inspection and surveillance of factory production control
  - (v) Ongoing audit testing in accordance with EN 1154 requirements
5. The process is approved on the basis of product surveillance under ISO 9001: 2008.
6. The approval relates to on-going production.
7. Approved products shall carry a label identified with the processor's name and contact number, the CERTIFIRE name, or name and mark, together with the CERTIFIRE certificate number and a unique serial number.
8. Doorframe kits shall be in accordance with the following specification.

## CERTIFICATE No CAF 109 HICKMAN INDUSTRIES LIMITED

### FIRE DOOR FRAMES & KITS – Max 2040 mm high door leaves.

#### Frame

25mm thick MDF grooved frame 77mm wide up to 159mm wide with either 14.5 x 23mm or 14.5 x 59mm MDF door stops. Grooved for intumescent seals.

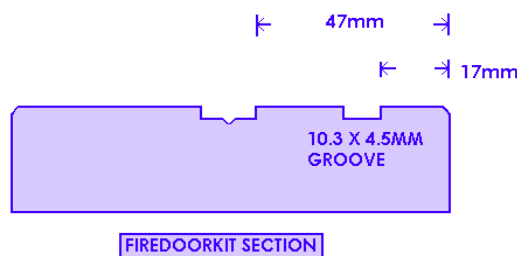

#### Ironmongery

3 number steel hinges (ref 1500-01) as certified under Certificate of Conformity number 1121 – CPD – AC0110, c/w 38 mm or 55 mm keeps fitted on the door. In addition a 63mm tubular latch or mortice sash lock also manufactured by Unity Locks and certificated under Certificate of Conformity numbers 1121 – CPD – AG0072 to AG0076, positioned as per drawing.

Doors may include Carlisle Brass Ltd.'s bathroom locks, model ref's: BAE5025NP/R and BTL2NP/R/BO.

CF198 doors may, as an alternative, be fitted on 3 number steel spring hinges referenced IFL7.01. These hinges shall only be fitted to latched door configurations and the hinges shall be provided with a bedding of 1.8 mm thick (minimum) intumescent sheet behind each blade.

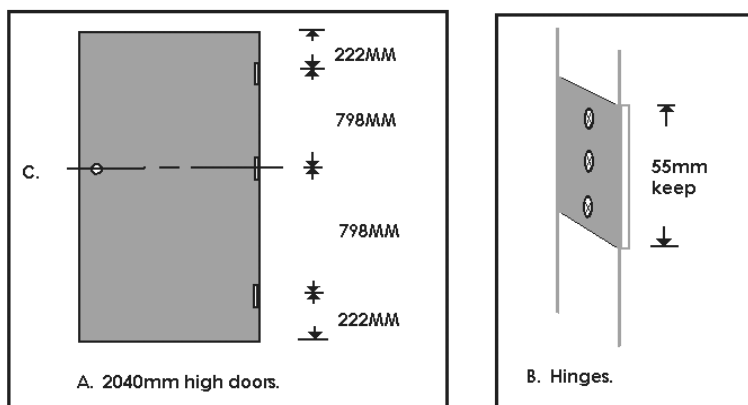

## CERTIFICATE No CAF 109 HICKMAN INDUSTRIES LIMITED

FIRE DOOR FRAMES & KITS – Max 2040 mm high door leaves.

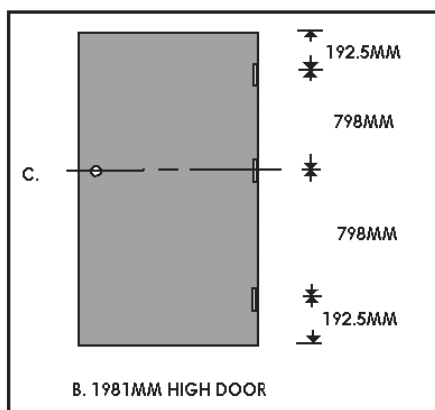

### Jamb Mounted Closers

Recessed cylindrical door closers are permitted to be used with the above mentioned doorkit references within the following constraints:

- i) On internal, single-leaf, single-acting, latched door assemblies
- ii) In single occupancy, domestic dwellings including on a door between an integral garage and the living accommodation
- iii) On internal doors ONLY within a single residence (flat) of multiple occupancy domestic dwellings
- iv) Use on individual entrance (flat entrance) doors and in common areas within multiple occupancy dwellings and flats and all industrial and commercial applications are expressly excluded.

**Note: use of jamb mounted closers are permitted on the basis that, when the door is latched shut, it will not detract from the fire performance of the door assembly in the event of a fire. The relevant door certificates should be checked to determine suitable jamb mounted closers.**

**The closing devices specified in the relevant certificates may not be CERTIFIRE approved and no claims should be made or should be implied or inferred on the ability of the device to close and latch the door or in respect of its mechanical performance or durability.**

## CERTIFICATE No CAF 109 HICKMAN INDUSTRIES LIMITED

**FIRE DOOR FRAMES & KITS – Max 2040 mm high door leaves.**

### Intumescent Seals

Doorset Specification	Configuration	Position	Intumescent Specification
CF 198	Single-acting Single-leaf	Head	Single 10mm x 4mm Lorient Polyproducts or Mann McGowan Palusol seal fitted into frame
		Vertical Edges	Single 10mm x 4mm Lorient Polyproducts or Mann McGowan Palusol seal fitted into frame
	Single-acting Double-leaf	Head	2 No. 10mm x 4mm thick Interdens seal fitted into leaf
		Hanging Edges	Single 10mm x 4mm thick Palusol based intumescent fitted into frame
		Meeting Edges	2 No. 10mm x 4mm thick Interdens <b>or</b> Palusol intumescent only. (One strip fitted into each leaf, strips should not oppose each other)
CF 218	Single-acting Single-leaf	Head	Single 10mm x 4mm Lorient Polyproducts or Mann McGowan Palusol seal fitted into frame
		Vertical Edges	Single 10mm x 4mm Lorient Polyproducts or Mann McGowan Palusol seal fitted into frame
	Single-acting Double-leaf	Head	Single 10mm x 4mm Lorient Polyproducts or Mann McGowan Palusol seal fitted into frame <b>AND</b> 15mm x 4mm Lorient Polyproducts or Mann McGowan Palusol seal in door leaf edge
		Hanging Edges	Single 10mm x 4mm Lorient Polyproducts or Mann McGowan Palusol seal fitted into frame <b>AND</b> 15mm x 4mm Lorient Polyproducts or Mann McGowan Palusol seal in door leaf edge
		Meeting Edges	Single 15mm x 4mm Lorient Polyproducts or Mann McGowan Palusol seal fitted in door leaf edge
CF 160	Single-acting Single-leaf	Head	Single 10mm x 4mm Lorient Polyproducts or Mann McGowan Palusol seal fitted into frame
		Vertical Edges	Single 10mm x 4mm Lorient Polyproducts or Mann McGowan Palusol seal fitted into frame
	Double-leaf	Head	Single 20 mm wide by 4 mm thick Therm-A-Seal or two opposing minimum 10 mm wide by 4 mm thick Therm-A-Seal in the leaf and frame.
		Vertical edges	Minimum 10 mm wide by 4 mm thick Therm-A-Seal in the centre of the frame reveal.
		Square radiused meeting stiles	A single 20 mm wide by 4 mm thick Therm-A-Seal or two non-opposing minimum 10 mm wide by 4 mm thick Therm-A-Seal offset by 2-3 mm.
		Rebated meeting stiles	Two minimum 10 mm wide by 4 mm Therm-A-Seal thick spaced 2-3 mm from the stop, one on each leaf.
CF 192	Single-acting Single-leaf	Head	Single 10mm x 4mm Lorient Polyproducts or Mann McGowan Palusol seal fitted into frame
		Vertical Edges	Single 10mm x 4mm Lorient Polyproducts or Mann McGowan Palusol seal fitted into frame





---

## CERTIFICATE No CAF 109 HICKMAN INDUSTRIES LIMITED

---

**FIRE DOOR FRAMES & KITS – Max 2040 mm high door leaves.**

### **Intumescent Seals (Continued)**

The previously specified seals may be replaced with alternative CERTIFIRE approved intumescent seals in line with Technical Schedule 35.

The CF198 doors may incorporate leaf to frame gaps of up to 6 mm and in this instance the door leaf is to be single-acting, single-leaf only and shall include a Palusol based 15 x 4mm intumescent strip within the leaf head in addition to the intumescent seals specified for installation within the door frame.

Notes: CF160 double-leaf doorsets provided by Hickman Industries Limited may be provided with reduced size (10 x 4 mm) intumescent seals in the frame head for periods of 20 minutes integrity performance (FD20)

CF160 double-leaf doorsets provided by Hickman Industries Limited may be provided with reduced size (10 x 4 mm) intumescent seals in the frame head with an additional surface fixed 20 x 0.5 mm Norseal Firefly intumescent sheet material fitted centrally on the top of the door leaf, for periods of 30 minutes integrity performance (FD30)

### **Smoke Seals**

Where smoke seals are specified they shall be CERTIFIRE approved for the application.



## CERTIFICATE No CAF 109 HICKMAN INDUSTRIES LIMITED

### FIRE DOOR FRAMES & KITS – PREMDOR CF198 DOORS (Max 2100 x 926mm)

#### CF198 Door Leaf sizes

Door assembly configuration	Maximum Height (mm)	Maximum Width (mm)	Area (m2)
Single-Acting, Single-Leaf Latched / Unlatched	2100 (at 926 wide)	926 (at 2100 high)	1.94
Single-Acting, Double-Leaf Latched / Unlatched	2100 (at 926 wide)	926 (at 2100 high)	1.94

Double-leaf doorsets including unequal sized door leaves are permitted on the assumption that the smaller leaf is no less than 30 % of the width of the larger leaf.

Under no circumstances must either the maximum height or maximum width be exceeded without separate CERTIFIRE approval.

Where door leaves are required with an increased leaf height of 2100 mm high an enhanced intumescent specification is required as detailed in table 2.

#### CF198 Intumescent specification

Door assembly Configuration	Position	Required Intumescent Protection
Single-Acting, Single-Leaf Latched / Unlatched	Frame Head	Single 10 mm wide by 4 mm thick Lorient Polyproducts Ltd Type 617 seal
	Frame Jambs	Single 10 mm wide by 4 mm thick Lorient Polyproducts Ltd Type 617 seal
	Top Edge of Door	Single 15 mm wide by 4 mm thick Lorient Polyproducts Ltd Type 617 seal
Single-Acting, Double-Leaf Latched / Unlatched	Frame Head	Single 10 mm wide by 4 mm thick Lorient Polyproducts Ltd P100 or Type 617 seal
	Frame Jambs	Single 10 mm wide by 4 mm thick Lorient Polyproducts Ltd P100 or Type 617 seal
	Meeting edges	Single 10 mm by 4 mm thick Lorient P100, Type 617 or Interdens seal in each meeting edge (not opposing)
	Top Edge of Doors	Single 15 mm wide by 4 mm thick Lorient Polyproducts Ltd Type 617 seal

Page 7 of 12 Signed  
E/224

Issued: 8<sup>th</sup> August 2000

Reissued: 5<sup>th</sup> July 2022

Valid to: 31<sup>st</sup> August 2022

## CERTIFICATE No CAF 109 HICKMAN INDUSTRIES LIMITED

### FIRE DOOR FRAMES & KITS – PREMDOR CF198 DOORS (Max 2100 x 926mm)

#### Door Frame Kits

Door frame kits, as certificated under the scope of CAF109, may include those for use with door leaves up to 2100 mm high, as defined in CF198 (Premdor Crosby FD30 Timber Doors). The drawings below provide details of the frames, hinge cut out preparation and hinge positions.

2130MM FD30 JAMB DETAIL

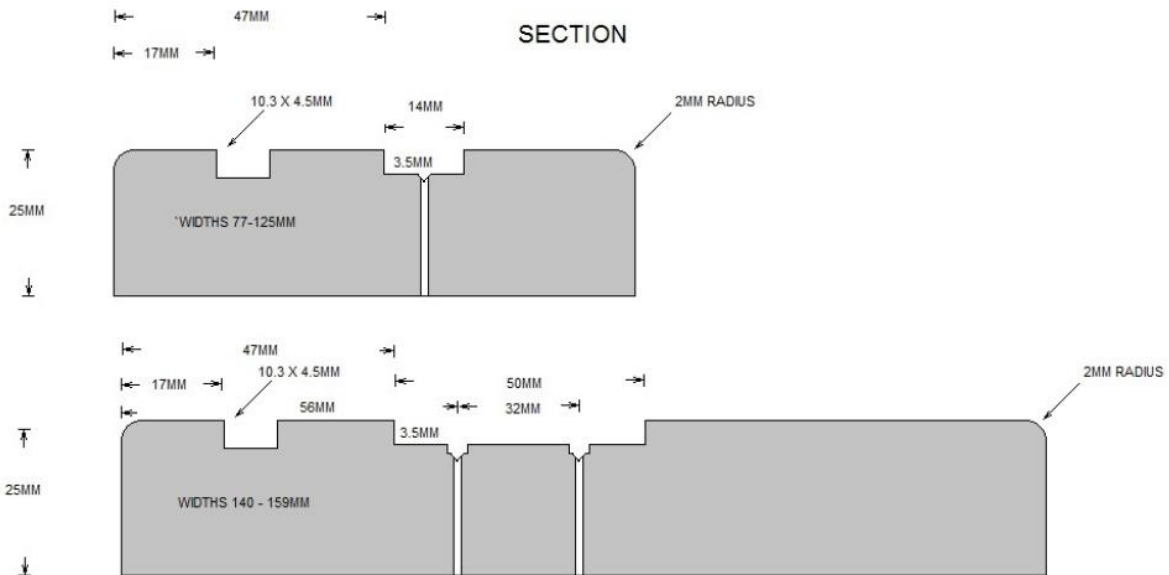

HOLES DRILLED 4MM DIA. C/SUNK FOR A MAX. 5MM (NO.10) FULL THREADED SCREWS.

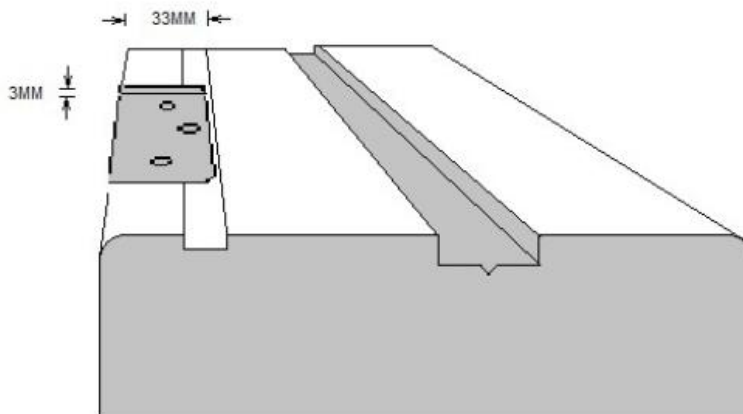



## CERTIFICATE No CAF 109 HICKMAN INDUSTRIES LIMITED

### FIRE DOOR FRAMES & KITS – PREMDOR CF198 DOORS (Max 2100 x 926mm)

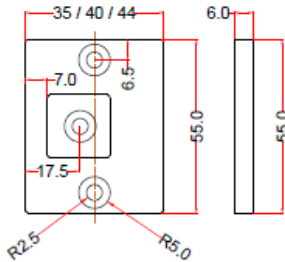

Through Hinge  
Must Be Pilot Holed  
Ø3mm x 15mm

Center Line		
C/L	Latch	Bathlock
(A)	1050	1050
(B)	44	44

Center Of Spindle Hole		
C/L	Latch	Bathlock
(A)	1050	1023.5
(B)	44	44

### Hickmans Oversized (2100mm) Servicing Drawing

Tolerances  
Dimensions from Top of Door  
+1.3mm / - 0mm  
Width / Length / Square Tolerances  
+0mm / -1mm  
Thickness  
+0mm / -0.5mm

Bathlock & Latch Servicing Detail  
on Drawing 100280

The Latch or Bathlock is to be  
Loose Fitted & Pilot Holed

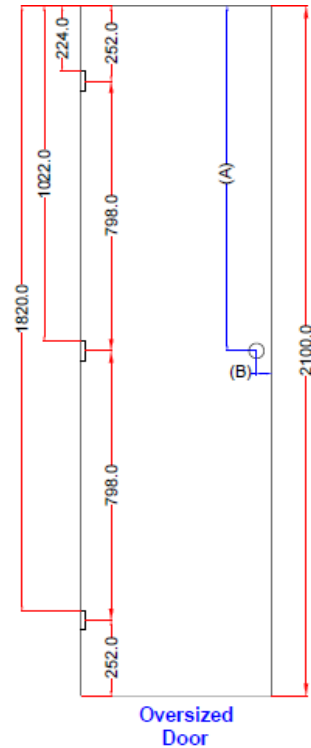

## CERTIFICATE No CAF 109 HICKMAN INDUSTRIES LIMITED

### FIRE DOOR FRAMES & KITS – JELD-WEN CF160 & CF192 DOORS (Max 2100 high)

Door frame kits, as certificated under the scope of CAF109, may include those for use with door leaves up to 2100 mm high, as defined in CF160 and CF192 (JELDWEN FD30 Timber Doors). The drawings below provide details of the frames, hinge cut out preparation and hinge positions.

2130MM FD30 JAMB DETAIL

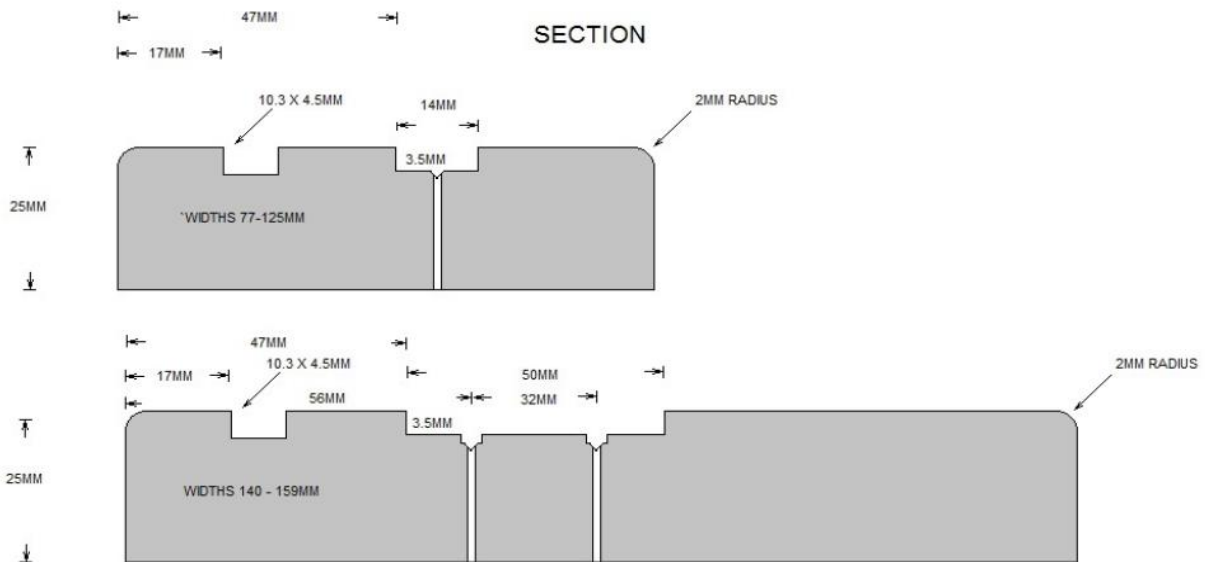

HOLES DRILLED 4MM DIA. C/SUNK FOR A MAX. 5MM (NO.10) FULL THREADED SCREWS.

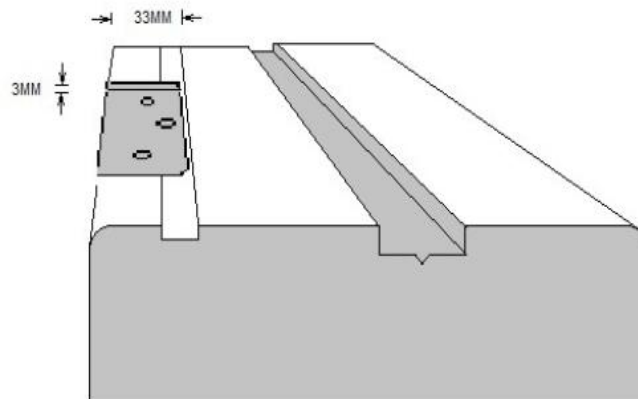

## CERTIFICATE No CAF 109 HICKMAN INDUSTRIES LIMITED

FIRE DOOR FRAMES & KITS – JELD-WEN CF160 & CF192 DOORS (Max 2100 high)

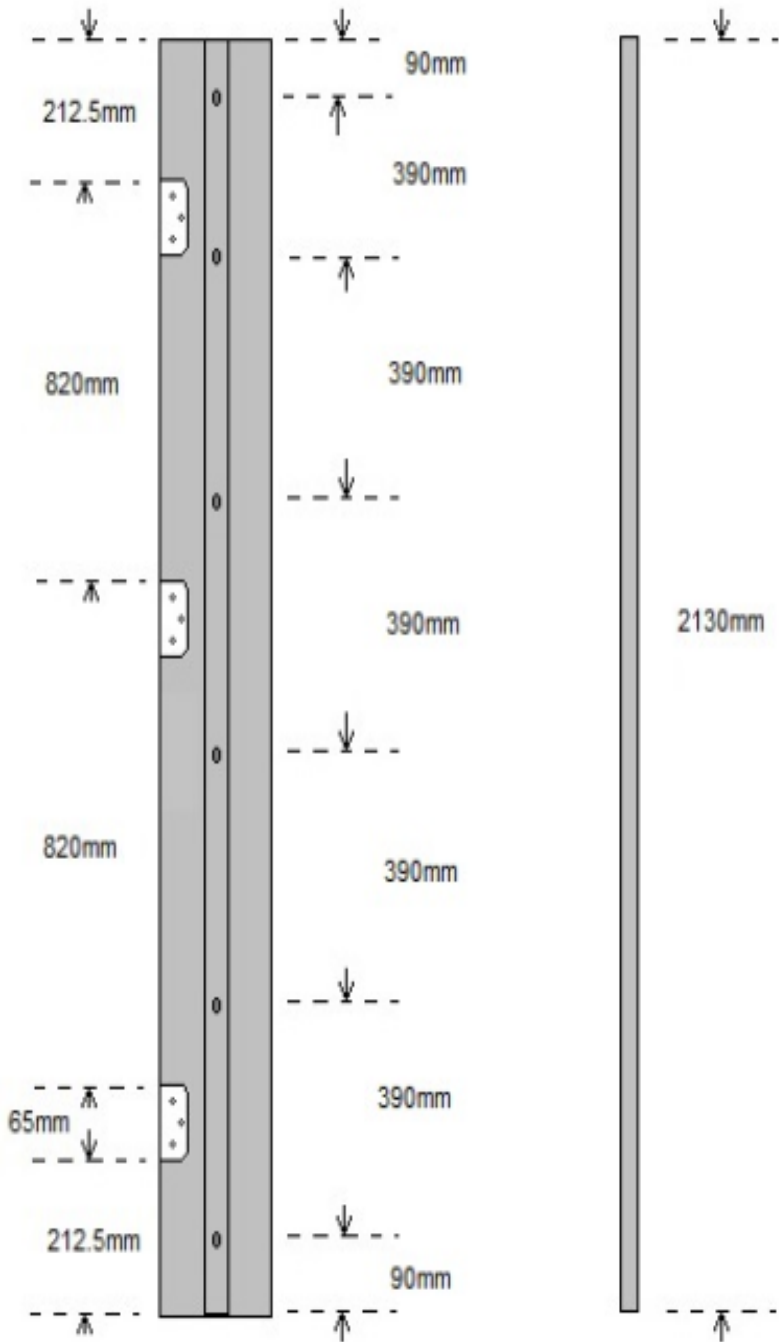

## CERTIFICATE No CAF 109 HICKMAN INDUSTRIES LIMITED

### GLAZED APERTURES and DOOR FRAMES (Vicaima Limited)

1. This approval relates to the cutting of apertures with or without glazing in doors supplied by Vicaima Limited and to the manufacture of doorframes. Subject to the undermentioned conditions, the doors will meet the requirements as detailed in the relevant certificates.
2. This certification is designed to demonstrate compliance of the product or system specifically with Approved Document B (England and Wales), Technical Handbook (Scotland), Technical Booklet E (N. Ireland). If compliance is required to other regulatory or guidance documents there may be additional considerations or conflict to be taken into account.
3. The certified doors for which the cutting of apertures, subsequent glazing thereof and provision of frames is approved are as following:

Vicaima Certificate No	Timber Door Product	Aperture Cutting	Glazing of Apertures	Manufacture of Frames	MDF Frames	Resizing
CF218	FD30 'SDC'	✓	✓	✓	✓	x
CF454	FD60	✓	✓	✓	✓	x

**Note:** The scope of approval and field of application for the doors is contained in the above referenced certificates.

4. Apertures, glazing and frames shall be in accordance with Vicaima Limited construction specifications and data sheets for the above referenced products.
5. Processing is conducted in accordance with Vicaima Limited procedures.
6. The process is approved on the basis of on-going certification of quality management system to ISO 9001:2008.
7. Inspection and surveillance of factory production control
8. The approval relates to on-going production.
9. Approved products carry both the original manufacturer's CERTIFIRE approval label and a second label identified with the processor's name and contact number, the CERTIFIRE name, or name and mark, together with the CERTIFIRE certificate number and a unique serial number.

